



ABS DEWATERING PUMPS.



You won't just see the difference. You will experience it.

Choose ABS and you will get much more than just the right pump. In a world where time is money, fast dewatering of a worksite is crucial. We can help you plan for efficient dewatering, in virtually any situation – construction sites, tunnels, mines, shipyards and dry docks.

At ABS, our interest in dewatering runs deep, but we do realize that for many users the main concern is for the water to go away - the sooner, the better. Let us worry about flow rates, pump selection, energy consumption and other specs. We will provide you with the best and most efficient solution.

More than 40 years of technical and real-world experience, has resulted in a complete range of submersible dewatering pumps. Changing needs over the project duration can make financing of a dewatering project a real challenge.

At ABS we offer pump solutions that include purchase, rental and service.

By making use of our extensive network of service centers and partners, problems can be resolved quickly and efficiently without disruptions to your schedules.





ABS submersible drainage pump J 4

Suitable for water, dirty water mixed with soil

Plug in start with built in motor protection

Light weight aluminium design

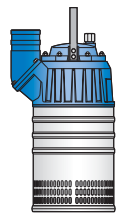

ABS submersible sludge pump JS 8

Suitable for sludge, water mixed with solids

Plug in start with built in motor protection

Light weight aluminium/nodular cast iron design

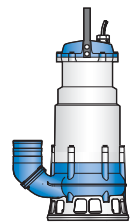

ABS submersible sludge pump JT 10

Suitable for sludge, water mixed with solids

Portable pump with handle, stand and discharge connection

Vortex hydraulic pump in cast iron

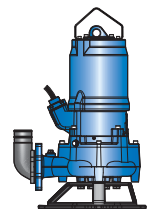

Pump options and accessories 13

**Tell us your need.
We provide the solution.**

- What you are pumping
- Requested flow
- Site conditions
- Time schedules
- Availability and logistics
- Need for emergency or back-up service
- Suitable mix of rent & buy
- Project planning
- Purchase, rental or leasing

ABS submersible drainage pump J

ABS submersible drainage pump J 5 - 604 and JC 24 - 84 are suitable for pumping water and dirty water mixed with soil. When delivered to a site you can start using them right away. The low weight and compact design vouches for convenient transport, handling and installation. Just plug and pump!

1 Easy start – plug-in without worrying about overheating

Built-in contactor connected to the thermal sensors in the stator windings protects the motor from overheating and features an automatic restart function.

2 Wear resistance – one investment, years of cost efficient pumping

Impeller in high chrome alloy steel with full upper shroud and adjustable wear parts in oil resistant nitrile rubber secure a long lifetime and high efficiency.

3 Reliable operation – minimizes time for maintenance

Double outer casing and good heat convection enables pump to operate continuously at low levels or even run dry without damaging the motor.

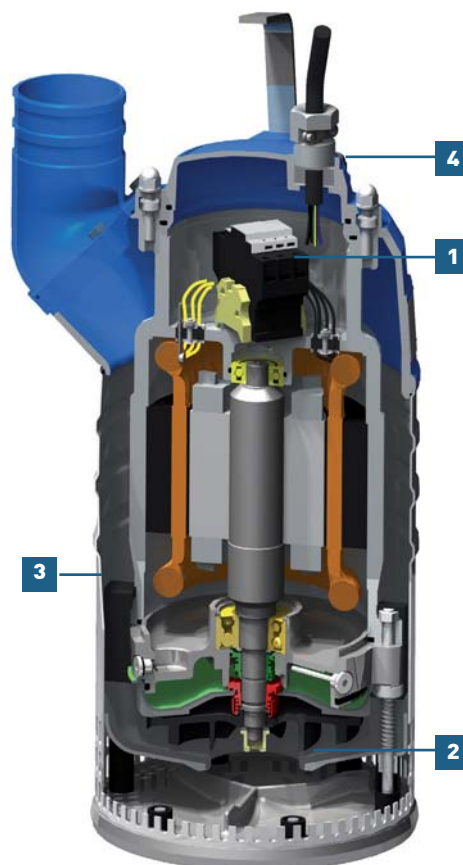

First class materials like outer casing in stainless steel, cast parts in lightweight aluminium alloy, mechanical shaft seals in silicon carbide grant a pump you can rely on.

4 Serviceability – save time and money by easy on-site service

Due to modular design, the same parts can be used for different pumps, which lowers overall service costs. By removing the top cover of the pump you can easily check the electrical junction box.

For protection the motor is separately sealed from the junction box. Environmentally safe white oil is used in the oil casing for easy inspection of seal conditions. For J205 and J405 service is made even easier due to a mechanical seal cartridge.

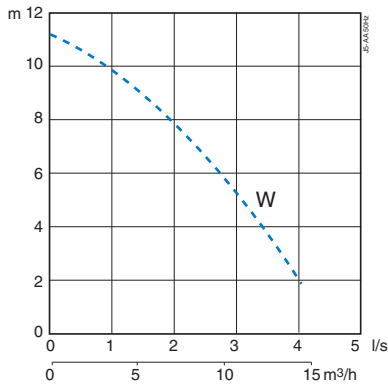

ABS J 5

J 5 W

Motor rating P_2	0.48 kW, 1 ~ 230
Voltage (V)	230
Full load (A)	2.9
Speed	2690 rpm
Strainer hole	6 mm
Discharge connections	Hose 2" Thread G/BSP 2"
Weight (excl. cable)	9.5 kg
Motor protection	built in
Electric cable	10 m S1BN8-F

1-phase

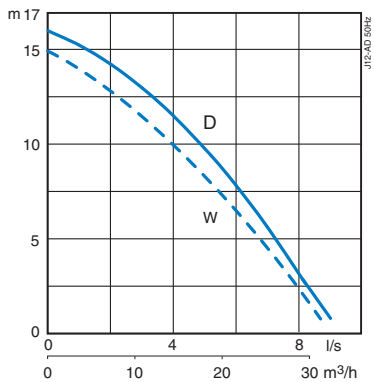
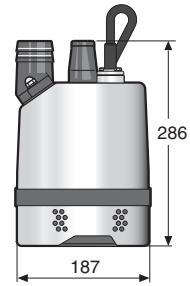

ABS J 12

J 12 W/J 12 WKS* J 12 D/J 12 DKS*

Motor rating P_2	0.9 kW, 1 ~ 230	1.0 kW, 3 ~ 230 / 400 / 500
Voltage (V)	110 / 230	230 / 400 / 500
Full load (A)	10.4 / 5.2	4.0 / 2.3 / 1.9
Speed	2750 rpm	2800 rpm
Strainer hole	6.5 x 22 mm	
Discharge connections	Hose 1½", 2", 2½", 3" Thread G/BSP 2", 2½", 3"	
Weight (excl. cable)	16 kg	
Motor protection	built in	
Electric cable	20 m S1BN8-F	

1-phase 3-phase

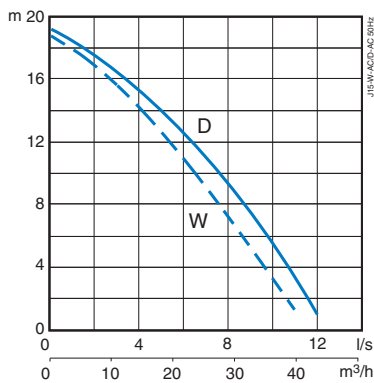
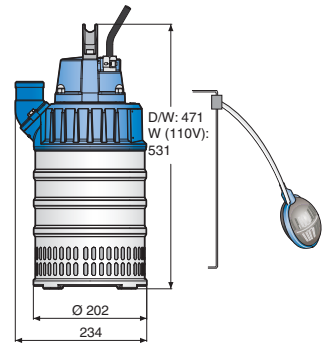

ABS J 15

J 15 W/J 15 WKS* J 15 D/J 15 DKS*

Motor rating P_2	1.4 kW, 1 ~ 230	1.4 kW, 3 ~ 230 / 400 / 500
Voltage (V)	230	230 / 400 / 500
Full load (A)	8.1	5.0 / 2.9 / 2.3
Speed	2800 rpm	2800 rpm
Strainer hole	6.5 x 22 mm	
Discharge connections	Hose 1½", 2", 2½", 3" Thread G/BSP 2", 2½", 3"	
Weight (excl. cable)	18 kg (W), 16.5 kg (D)	
Motor protection	built in	
Electric cable	20 m S1BN8-F	

1-phase 3-phase

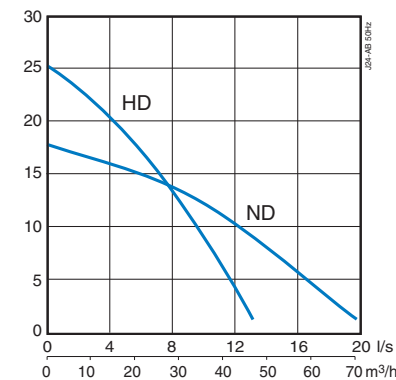
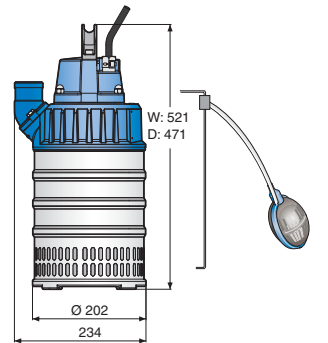

ABS J 24

J 24 ND J 24 HD

Motor rating P_2	2.3 kW, 3 ~ 230 / 400 / 500 / 1000
Voltage (V)	230 / 400 / 500 / 1000
Full load (A)	8.4 / 4.8 / 3.8 / 1.9
Speed	2870 rpm
Strainer hole	7.5 x 22 mm
Discharge connections	Hose 2½", 3", 4" Thread G/BSP 2½", 3", 4"
Weight (excl. cable)	29 kg
Motor protection	built in
Electric cable	20 m S1BN8-F

Medium head High head

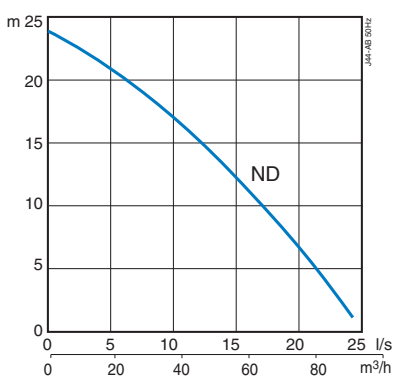
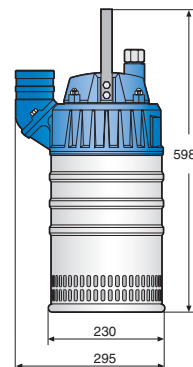

ABS J 44

J 44 ND

Motor rating P_2	3.9 kW, 3 ~ 230 / 400 / 500 / 1000
Voltage (V)	230 / 400 / 500 / 1000
Full load (A)	14.1 / 8.1 / 6.5 / 3.2
Speed	2870 rpm
Strainer hole	7.5 x 22 mm
Discharge connections	Hose 2½", 3", 4" Thread G/BSP 2½", 3", 4"
Weight (excl. cable)	31 kg
Motor protection	built in
Electric cable	20 m S1BN8-F

Medium head

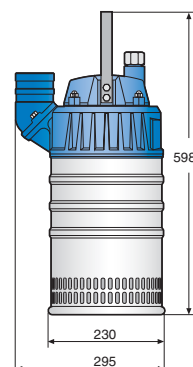

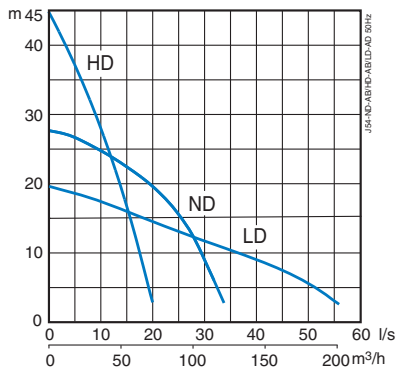

ABS J 54

J 54 ND
J 54 HD
J 54 LD

Motor rating P_2	5.8 kW, 3 ~
Voltage (V)	230 / 400 / 500 / 1000
Full load (A)	21 / 12 / 9.2 / 4.6
Speed	2850 rpm
Strainer hole	7.5 x 22 mm
Discharge connections	Hose 3", 4", 6" Thread G/BSP 3", 4", 6"
Weight (excl. cable)	50 kg
Motor protection	built in
Electric cable	20 m S1BN8-F

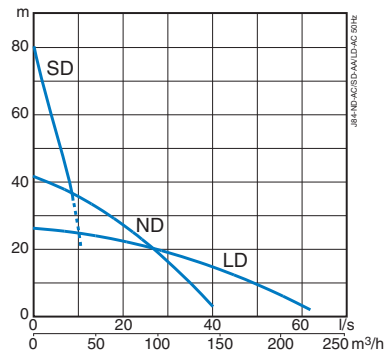
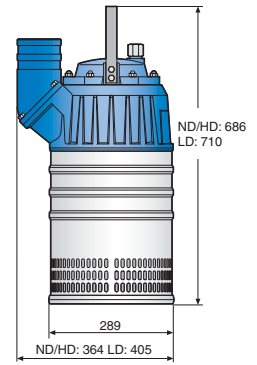

ABS J 84

J 84 ND
J 84 SD
J 84 LD

Motor rating P_2	9.4 kW, 3 ~
Voltage (V)	230 / 400 / 500 / 1000
Full load (A)	31 / 18 / 14 / 7
Speed	2850 rpm
Strainer hole	7.5 x 22 mm
Discharge connections	Hose 3", 4", 6" Thread G/BSP 3", 4", 6"
Weight (excl. cable)	60 kg (ND, LD), 67 kg (SD)
Motor protection	built in
Electric cable	20 m S1BN8-F

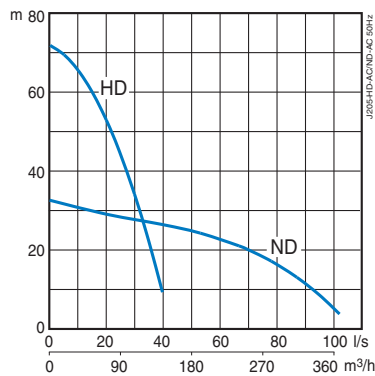
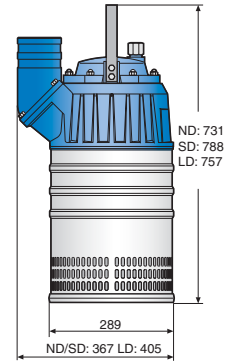

ABS J 205

J 205 ND
J 205 HD

Motor rating P_2	21 kW, 3 ~
Voltage (V)	230 / 400 / 500 / 1000
Full load (A)	68 / 39 / 31 / 16
Speed	2930 rpm
Strainer hole	8 x 34 mm
Discharge connections	Hose 4", 6", 8" Thread G/BSP 4", 6", 8"
Weight (excl. cable)	155 kg
Motor protection	built in
Electric cable	20 m S1BN8-F

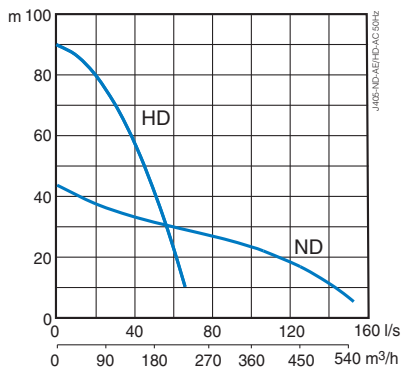
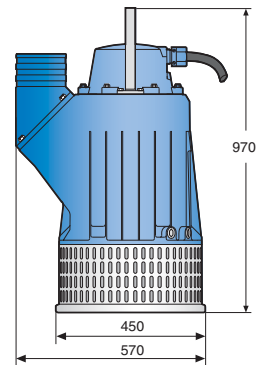

ABS J 405

J 405 ND
J 405 HD

Motor rating P_2	35 kW, 3 ~
Voltage (V)	230 / 400 / 500 / 1000
Full load (A)	108 / 62 / 50 / 25
Speed	2945 rpm
Strainer hole	8 x 34 mm
Discharge connections	Hose 4", 6", 8" Thread G/BSP 4", 6", 8"
Weight (excl. cable)	270 kg
Motor protection	thermal overload sensors
Electric cable	20 m S1BN8-F

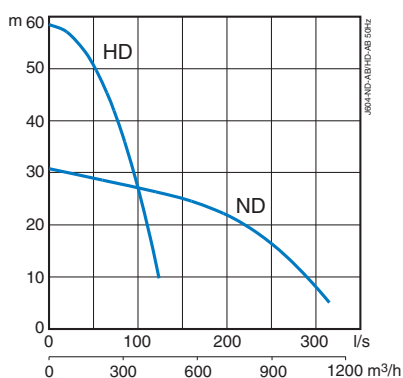
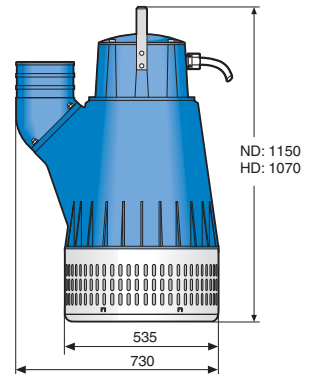

ABS J 604

J 604 ND
J 604 HD

Motor rating P_2	56 kW, 3 ~
Voltage (V)	230 / 400 / 500 / 1000
Full load (A)	184 / 106 / 84 / 42
Speed	1450 rpm
Strainer hole	12 x 60 mm
Discharge connections	Hose 6", 8", 10" Thread G/BSP 6", 8"
Weight (excl. cable)	525 kg
Motor protection	thermal overload sensors
Electric cable	20 m S1BN8-F

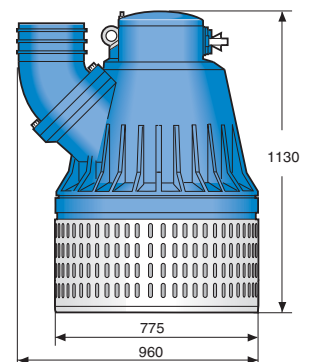

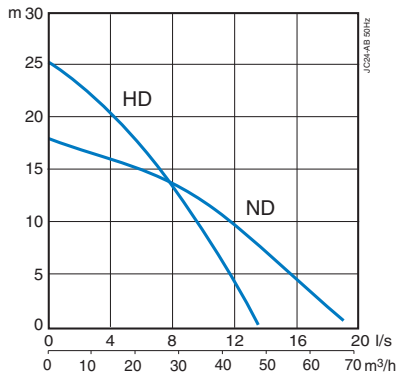

ABS JC 24

JC 24 ND
JC 24 HD

Motor rating P ₂	2.3 kW, 3 ~
Voltage (V)	230 / 400 / 500
Full load (A)	8.4 / 4.8 / 3.8
Speed	2870 rpm
Strainer hole	7.5 x 22 mm
Discharge connections	Thread G/BSP 3"
Weight (excl. cable)	29 kg
Motor protection	built in
Electric cable	20 m S1BN8-F

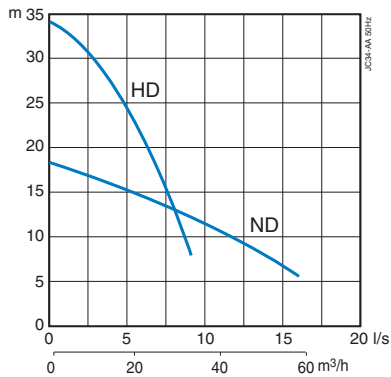
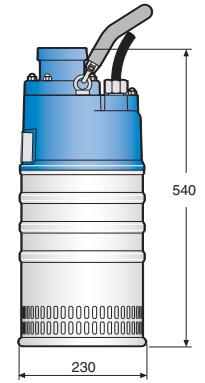

ABS JC 34

JC 34 ND
JC 34 HD

Motor rating P ₂	3.0 kW, 3 ~
Voltage (V)	230 / 400 / 500
Full load (A)	12.7 / 7.3 / 5.5
Speed	2850 rpm
Strainer hole	8 x 33 mm
Discharge connections	Hose 2", 3" Thread G/BSP 2", 3"
Weight (excl. cable)	31 kg
Motor protection	built in
Electric cable	20 m S1BN8-F

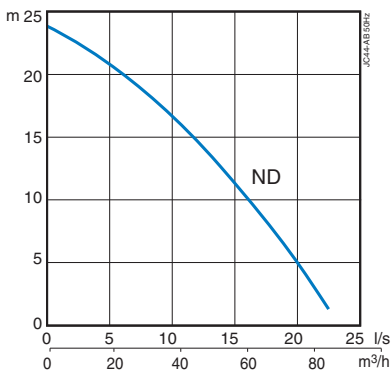
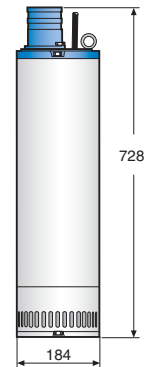

ABS JC 44

JC 44 ND

Motor rating P ₂	3.9 kW, 3 ~
Voltage (V)	230 / 400 / 500
Full load (A)	14.1 / 8.1 / 6.5
Speed	2870 rpm
Strainer hole	7.5 x 22 mm
Discharge connections	Thread G/BSP 3"
Weight (excl. cable)	31 kg
Motor protection	built in
Electric cable	20 m S1BN8-F

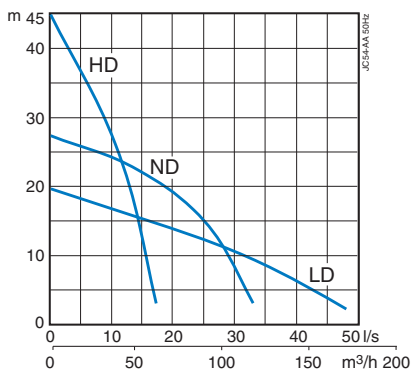
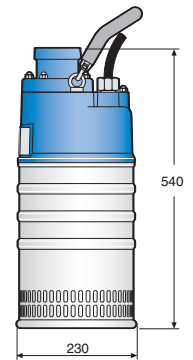

ABS JC 54

JC 54 ND
JC 54 HD
JC 54 LD

Motor rating P ₂	5.8 kW, 3 ~
Voltage (V)	230 / 400 / 500
Full load (A)	21 / 12 / 9.2
Speed	2850 rpm
Strainer hole	7.5 x 22 mm
Discharge connections	Thread G/BSP 3", 4"
Weight (excl. cable)	50 kg
Motor protection	built in
Electric cable	20 m S1BN8-F

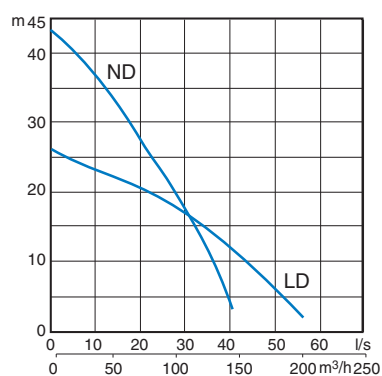
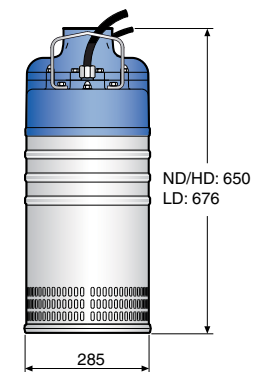

ABS JC 84

JC 84 ND
JC 84 LD

Motor rating P ₂	9.4 kW, 3 ~
Voltage (V)	230 / 400 / 500
Full load (A)	31 / 18 / 14
Speed	2850 rpm
Strainer hole	7.5 x 22 mm
Discharge connections	Thread G/BSP 3", 4"
Weight (excl. cable)	70 kg
Motor protection	built in
Electric cable	20 m S1BN8-F

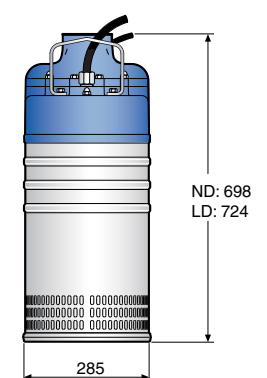

ABS submersible sludge pump JS

ABS submersible sludge pump JS 12 - 84 are excellent for pumping sludge and water mixed with solids. They have a slim design and low weight, which makes them easy to move and easy to handle. Once a JS pump is installed it can run without risk of overheating the motor or sludge clogging.

1 Easy start

– plug-in without worrying about overheating

Built-in contactor connected to the thermal sensors in the stator windings protects the motor from overheating and features an automatic restart function.

2 Clog-free pumping

– avoid downtime with solid proof hydraulics

Equipped with a free flow vortex impeller and a pump volute, the JS is perfect for pumping solids. The impeller is available in different sizes to meet your specific requirement. Max impeller diameter requires half motor or more submersed for continuous duty. (Pump can operate lying down.) Smaller impeller diameter for duty with low water level or intermittent dry running.

3 Reliability and wear resistance

– one investment, years of cost-efficient pumping

Both impeller and pump housing are made from wear resistant ductile

iron for maximum wear resistance and durability. Double mechanical shaft seal in oil bath with primary seal in silicon carbide secure safe operation and long life.

4 Convenient handling

– designed to make your life easier

All motor parts are made in light weight aluminium, which provides a pump that is very easy to handle and install.

5 Serviceability

– save time and money by easy and on-site service

Due to modular design, the same parts can be used for different pumps, which lower overall service costs. By removing the top cover of the pump you can easily check the electrical junction box. For protection the motor is separately sealed from the junction box. Environmentally safe white oil is used in the oil casing for easy inspection of seal conditions.

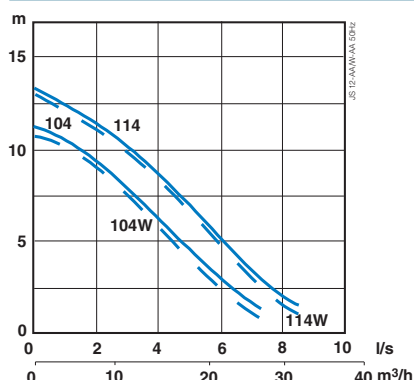
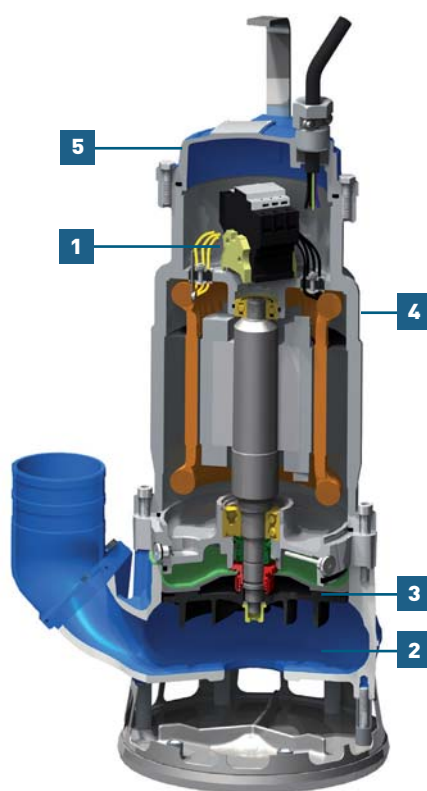

ABS JS 12

JS 12 W/WKS* -104/-114
JS 12 D/DKS* -104/-114

Motor rating P₂
Voltage (V)
Full load (A)
Speed
Free passage
Discharge connections

Weight (excl. cable)
Motor protection
Electric cable

1-phase
3-phase

0.9 kW, 1 ~ 230
5.1
2850 rpm
45 x 40 mm
Hose 2", 2½", 3"
Thread G/BSP 2", 2½", 3"

0.9 kW, 3 ~ 230 / 400 / 500
3.3 / 1.9 / 1.5
2850 rpm
20 m S1BN8-F

*) Built in float switch available as option.

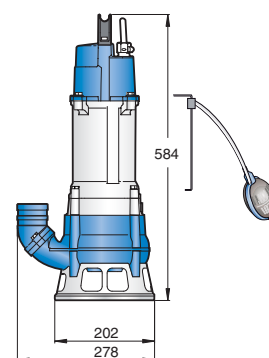

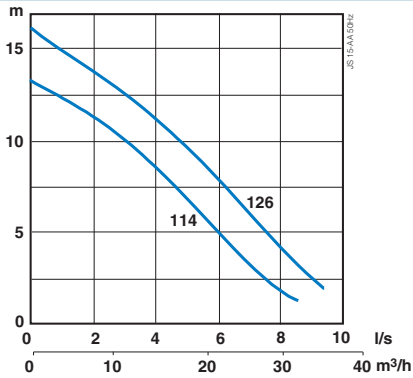

ABS JS 15

JS 15D/DKS* -114
JS 15D/DKS* -126

Motor rating P₂ 1.3 kW, 3 ~
Voltage (V) 230 / 400 / 500
Full load (A) 4.5 / 2.6 / 2.1
Speed 2850 rpm
Free passage 45 x 40 mm
Discharge connections Hose 2", 2½", 3"
Thread G/BSP 2", 2½", 3"
Weight (excl. cable) 18 kg
Motor protection built-in
Electric cable 20 m S1BN8-F

*1 Built in float switch available as option.

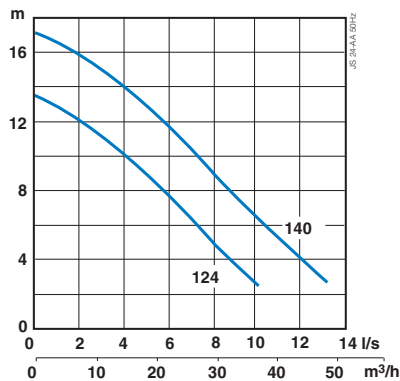
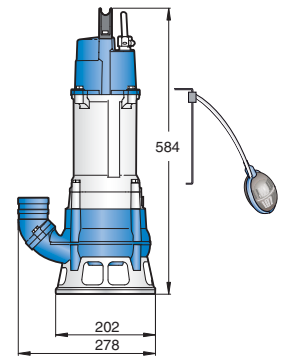

ABS JS 24

JS 24D/DKS* -124
JS 24D/DKS* -140

Motor rating P₂ 2.0 kW, 3 ~
Voltage (V) 230 / 400 / 500
Full load (A) 7.3 / 4.2 / 3.4
Speed 2870 rpm
Free passage 55 x 40 mm
Discharge connections Hose 2½", 3", 4"
Thread G/BSP 2½", 3", 4"
Weight (excl. cable) 29 kg
Motor protection built-in
Electric cable 20 m S1BN8-F

*1 Built in float switch available as option.

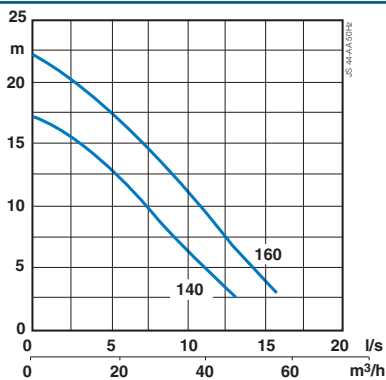
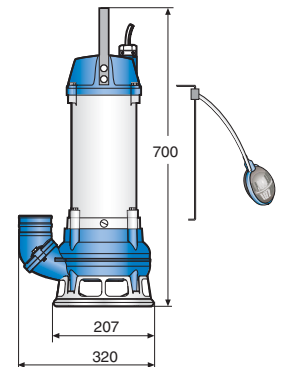

ABS JS 44

JS 44D/DKS* -140
JS 44D/DKS* -160

Motor rating P₂ 3.3 kW, 3 ~
Voltage (V) 230 / 400 / 500
Full load (A) 12 / 6.9 / 5.5
Speed 2870 rpm
Free passage 55 x 40 mm
Discharge connections Hose 2½", 3", 4"
Thread G/BSP 2½", 3", 4"
Weight (excl. cable) 31 kg
Motor protection built-in
Electric cable 20 m S1BN8-F

*1 Built in float switch available as option.

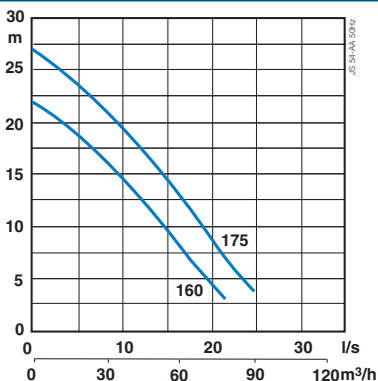
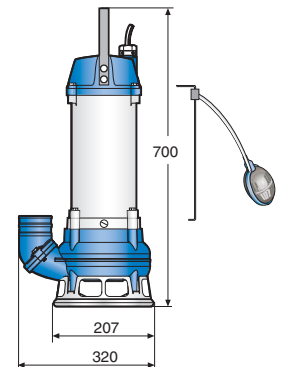

ABS JS 54

JS 54D/DKS* -160
JS 54D/DKS* -175

Motor rating P₂ 5.2 kW, 3 ~
Voltage (V) 230 / 400 / 500
Full load (A) 19.1 / 11 / 8.4
Speed 2850 rpm
Free passage 55 x 45 mm
Discharge connections Hose 3", 4"
Thread G/BSP 3", 4"
Weight (excl. cable) 54 kg
Motor protection built-in
Electric cable 20 m S1BN8-F

*1 Built in float switch available as option

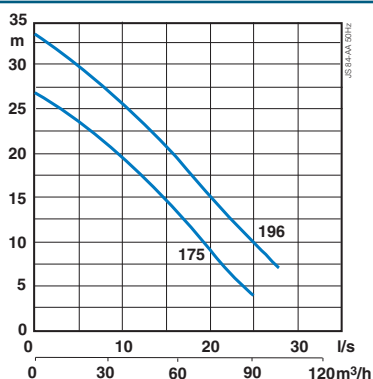
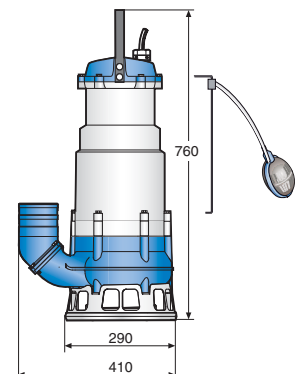

ABS JS 84

JS 84D/DKS* -175
JS 84D/DKS* -196

Motor rating P₂ 8.0 kW, 3 ~
Voltage (V) 230 / 400 / 500
Full load (A) 27.8 / 16 / 12.2
Speed 2850 rpm
Free passage 55 x 45 mm
Discharge connections Hose 3", 4"
Thread G/BSP 3", 4"
Weight (excl. cable) 67 kg
Motor protection built-in
Electric cable 20 m S1BN8-F

*1 Built in float switch available as option

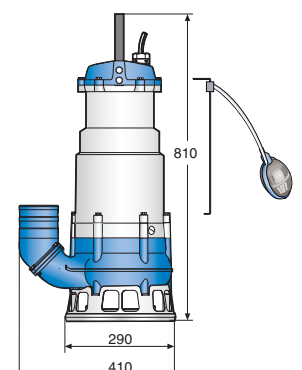

ABS submersible sludge pump JT

ABS submersible sludge pump JT 15 - 250 are suitable for pumping sludge and water mixed with solids. The robust cast iron design provides a sturdy pump for rough conditions. The pump runs at any water level without overloading the motor.

1 Dry running capability – no need for pump operation checks

Closed cooling jacket systems and an automatic stop and restart function with starter box enables dry running without damaging the mechanical seals or motor.

2 Clog-free pumping – avoid downtime with solid proof hydraulics

Equipped with a free flow vortex impeller and a pump volute, the JT is excellent for effective pumping of solids.

3 Convenient handling – designed to make your life easier

The stand in nodular cast iron and the stainless steel handle makes the JT easy to move and install. A hose or quick coupling is easily connected to the discharge connection supplied with the pump.

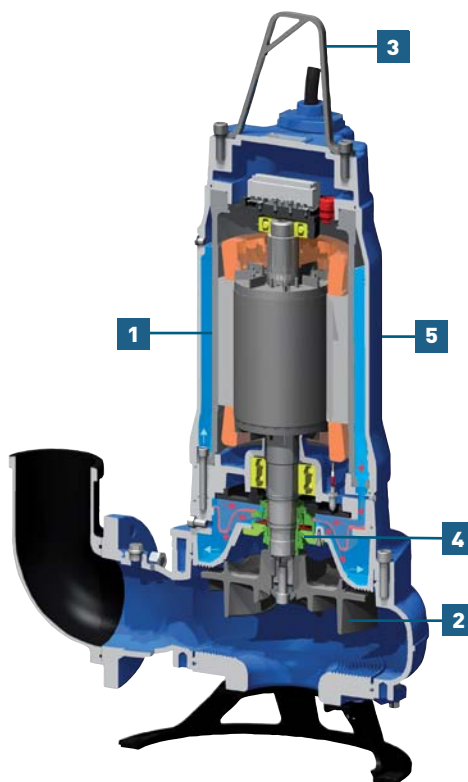

4 Reliability – one investment, years of cost efficient pumping

ABS vortex hydraulic requires no adjustment of impeller/wear plate. It minimizes load on shaft and bearings, which ensures reliable operation and maintained efficiency. All JT sludge pumps have mechanical seal in silicon carbide securing safe operation and long life.

5 Serviceability – save time and money with easy and on-site service

Modular design enables usage of the same parts for different pumps, which lowers overall service costs and increases flexibility. ABS JT40-250 pumps have mechanical seal cartridge, simplifying service on site

6 Safety features – minimizes unpleasant consequences

All JT sludge pumps are available in explosion proof EExd IIB T4 / ATEX versions. The oil housing on the JT15 - 30 is filled with safe white oil and on the JT 40 - 250 with environmentally safe glycol coolant.

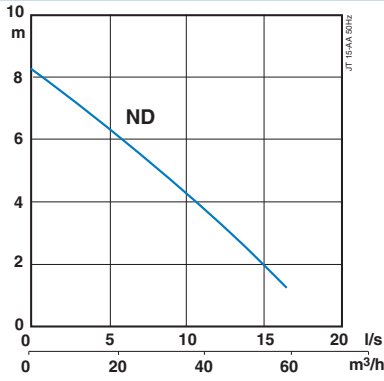

ABS JT 15

Type

Motor rating P_2
Voltage (V)
Full load (A)
Speed
Free passage
Discharge connections

Volute flange
Weight (excl. cable)
Motor protection
Electric cable

JT 15 ND (AS 0830)

1.3 kW, 3 ~
230 / 400 / 500
6.26 / 3.6 / 2.8
1330 rpm
60 mm
Hose 3"
Thread G/BSP 3"
DN 80
47 kg
thermal overload sensors
20 m S1BN8-F

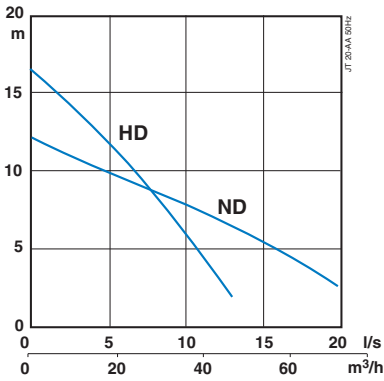
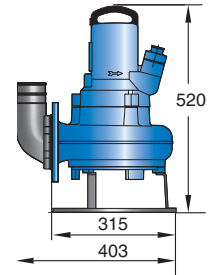

ABS JT 20

Type

Motor rating P_2
Voltage (V)
Full load (A)
Speed
Free passage
Discharge connections

Volute flange
Weight (excl. cable)
Motor protection
Electric cable

JT 20 HD (AS 0631)

1.7 kW, 3 ~
230 / 400 / 500
6.9 / 4 / 3.18
2800 rpm
40 mm
Hose 3"
Thread G/BSP 3"
DN 65
41 kg
thermal overload sensors
20 m S1BN8-F

JT 20 ND (AS 0830)

2.2 kW, 3 ~
230 / 400 / 500
8.96 / 5.2 / 4.12
1380 rpm
60 mm
Hose 3"
Thread G/BSP 3"
DN 80
47 kg
thermal overload sensors
20 m S1BN8-F

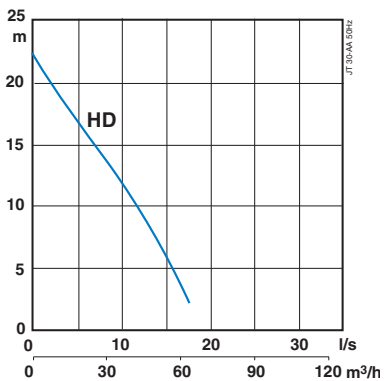
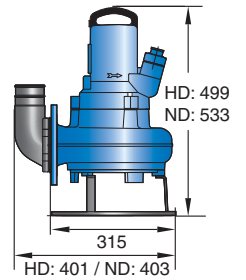

ABS JT 30

Type

Motor rating P_2
Voltage (V)
Full load (A)
Speed
Free passage
Discharge connections

Volute flange
Weight (excl. cable)
Motor protection
Electric cable

JT 30 HD (AS 0631)

3.0 kW, 3 ~
230 / 400 / 500
10.8 / 6.2 / 4.98
2835 rpm
40 mm
Hose 3"
Thread G/BSP 3"
DN 65
48 kg
thermal overload sensors
20 m S1BN8-F

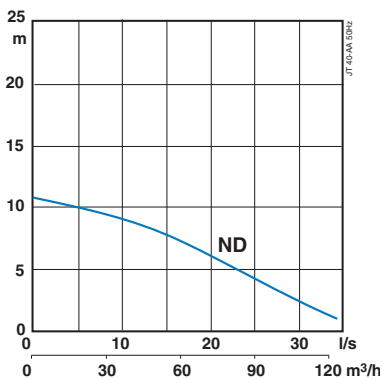
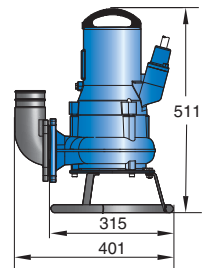

ABS JT 40

Type

Motor rating P_2
Voltage (V)
Full load (A)
Speed
Free passage
Discharge connections

Volute flange
Weight (excl. cable)
Motor protection
Electric cable

JT 40 ND (AFPK 1031)

3.0 kW, 3 ~
230 / 400 / 500
12.2 / 7 / 5.6
1370 rpm
100 mm
Hose 4"
Thread G/BSP 4"
DN 100
111 kg
thermal overload sensors
20 m S1BN8-F

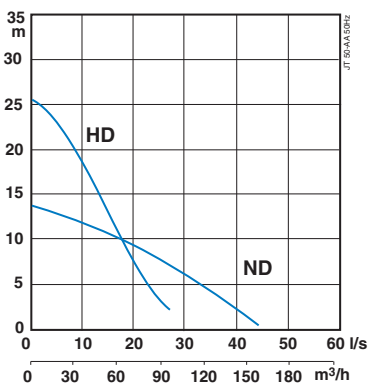
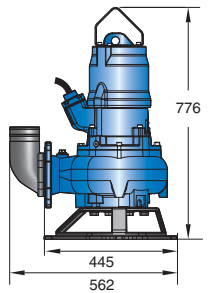

ABS JT 50

Type

Motor rating P_2
Voltage (V)
Full load (A)
Speed
Free passage
Discharge connections

Volute flange
Weight (excl. cable)
Motor protection
Electric cable

JT 50 HD (AFPK 0835)

5.5 kW, 3 ~
230 / 400 / 500
18.1 / 10.4 / 8.31
2885 rpm
65 mm
Hose 3"
Thread G/BSP 3"
DN 80
153 kg
thermal overload sensors
20 m S1BN8-F

JT 50 ND (AFPK 1032)

6.0 kW, 3 ~
230 / 400 / 500
21.8 / 12.5 / 10
1430 rpm
100 mm
Hose 4"
Thread G/BSP 4"
DN 100
147 kg
thermal overload sensors
20 m S1BN8-F

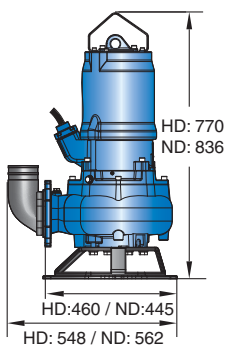

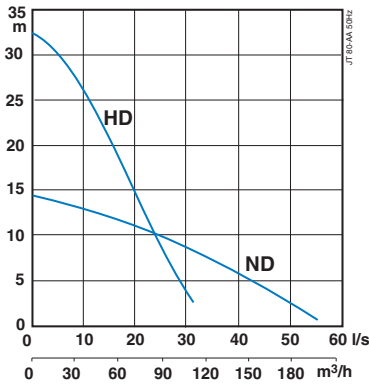

ABS JT 80

Type

Motor rating P_2
Voltage (V)
Full load (A)
Speed
Free passage
Discharge connections

Volute flange
Weight (excl. cable)
Motor protection
Electric cable

JT 80 HD (AFPK 0835)

7.0 kW, 3 ~
230 / 400 / 500
23.7 / 13.6 / 10.9
2875 rpm
65 mm
Hose 4"
Thread G/BSP 4"

DN 80
153 kg
thermal overload sensors
20 m S1BN8-F

JT 80 ND (AFPK 1032)

9.0 kW, 3 ~
230 / 400 / 500
33.7 / 19.4 / 15.5
1425 rpm
100 mm
Hose 4"
Thread G/BSP 4"

DN 100
157 kg
thermal overload sensors
20 m S1BN8-F

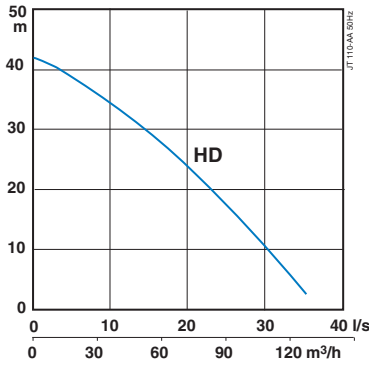
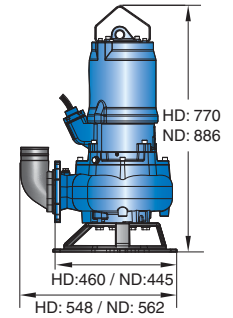

ABS JT 110

Type

Motor rating P_2
Voltage (V)
Full load (A)
Speed
Free passage
Discharge connections

Volute flange
Weight (excl. cable)
Motor protection
Electric cable

JT 110 HD (AFPK 0835)

11.0 kW, 3 ~
230 / 400 / 500
38.4 / 22.1 / 17.7
2900 rpm
65 mm
Hose 4"
Thread G/BSP 4"

DN 80
165 kg
thermal overload sensors
20 m S1BN8-F

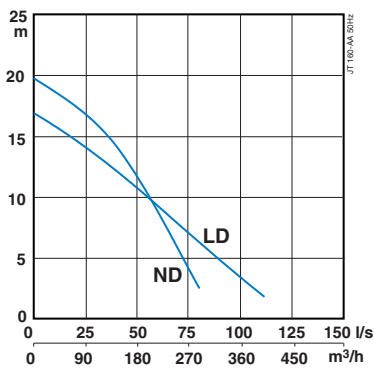
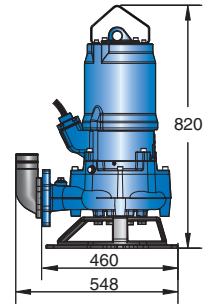

ABS JT 160

Type

Motor rating P_2
Voltage (V)
Full load (A)
Speed
Free passage
Discharge connections

Volute flange
Weight (excl. cable)
Motor protection
Electric cable

JT 160 ND (AFPK 1033)

16.0 kW, 3 ~
230 / 400 / 500
53.8 / 31 / 24.8
1460 rpm
80 mm
Hose 4"
Thread G/BSP 4"

DN 100
346 kg
thermal overload sensors
20 m S1BN8-F

JT 160 LD (AFPK 1533)

16.0 kW, 3 ~
230 / 400 / 500
53.8 / 31 / 24.8
1460 rpm
80 mm
Hose 6"
Thread G/BSP 6"

DN 150
358 kg
thermal overload sensors
20 m S1BN8-F

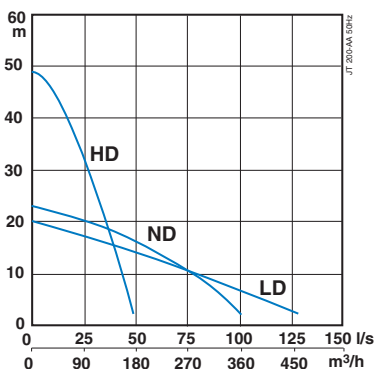
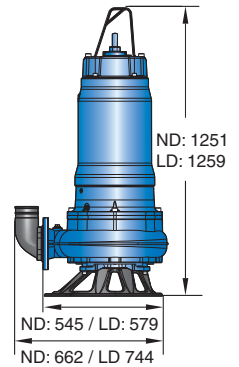

ABS JT 200

Type

Motor rating P_2
Voltage (V)
Full load (A)
Speed
Free passage
Discharge connections

Volute flange
Weight (excl. cable)
Motor protection
Electric cable

JT 200 HD (AFPK 1035)

20.0 kW, 3 ~
230/400/500
64.4/37/29.6
2945 rpm
64 mm
Hose 4"
Thread G/BSP 4"

DN 100
286 kg
thermal overload sensors
20 m S1BN8-F

JT 200 ND (AFPK 1033)

22.0 kW, 3 ~
230/400/500
73.5/42.3/33.8
1455 rpm
80 mm
Hose 4"
Thread G/BSP 4"

DN 100
351 kg
thermal overload sensors
20 m S1BN8-F

JT 200 LD (AFPK 1533)

22.0 kW, 3 ~
230/400/500
73.5/42.3/33.8
1455 rpm
80 mm
Hose 6"
Thread G/BSP 6"

DN 150
363 kg
thermal overload sensors
20 m S1BN8-F

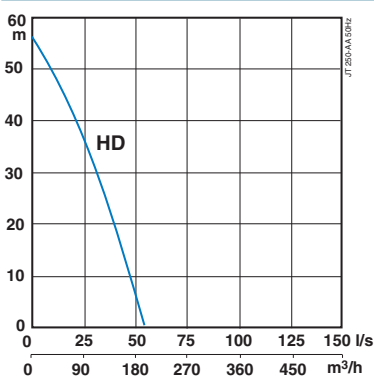
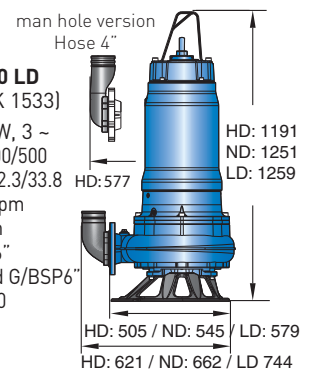

ABS JT 250

Type

Motor rating P_2
Voltage (V)
Full load (A)
Speed
Free passage
Discharge connections

Volute flange
Weight (excl. cable)
Motor protection
Electric cable

JT 250 HD (AFPK 1035)

25.0 kW, 3 ~
230 / 400 / 500
81.9 / 47.1 / 37.7
2950 rpm
64 mm
Hose 4"
Thread G/BSP 4"

DN 100
291 kg
thermal overload sensors
20 m S1BN8-F

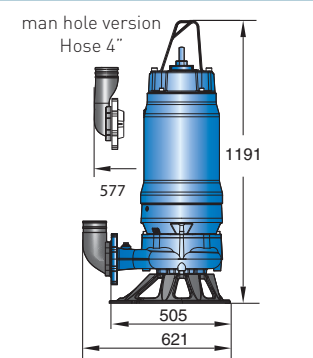

Pump options and accessories

The ABS dewatering solution offer goes beyond just the pump. In order to simplify the life of our customers we offer a wide selection of options and accessories.

This toolbox assures that you will get a solution that fits your application.

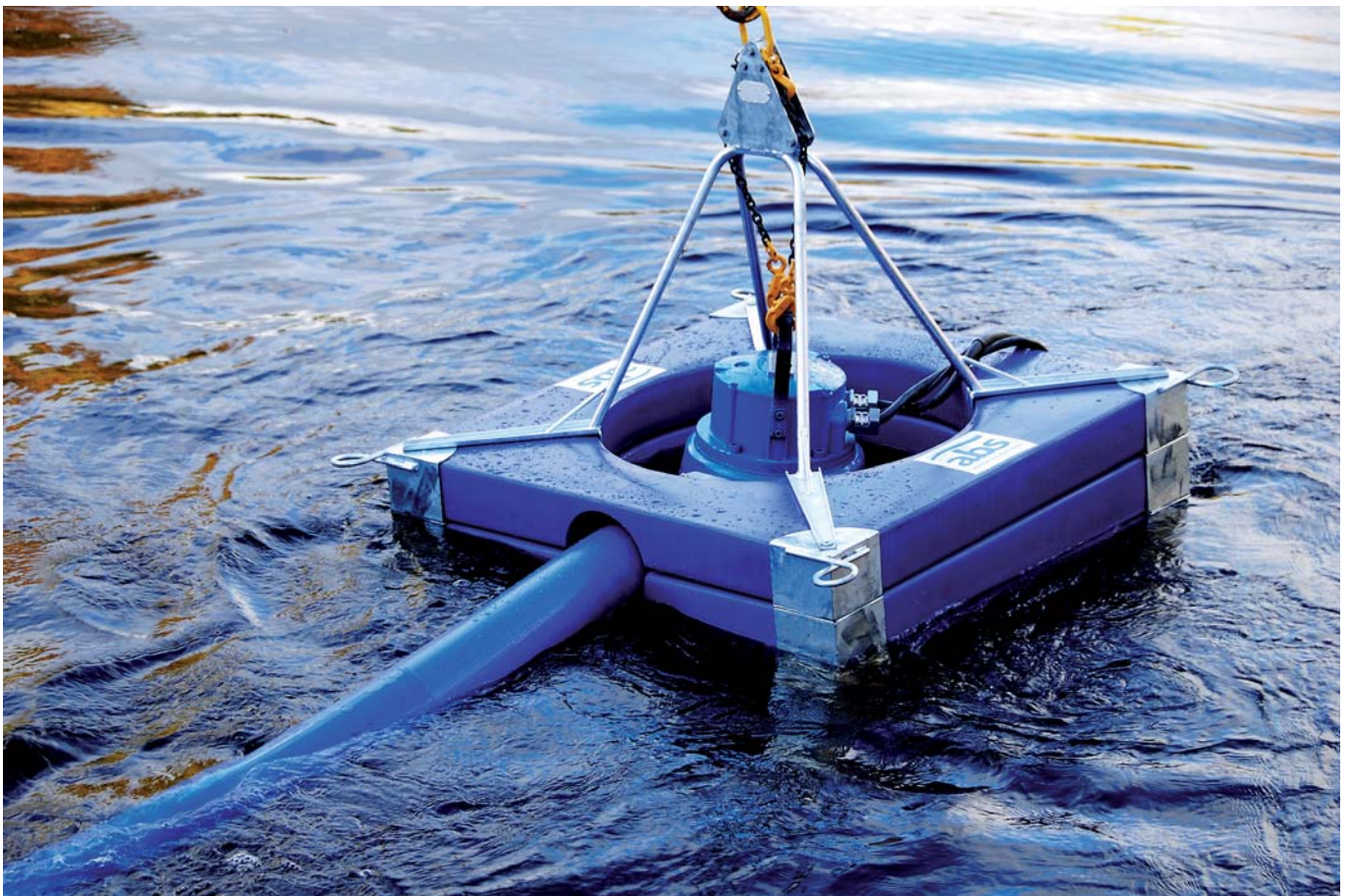



Additional protection for more durable operation

ABS submersible dewatering pumps can easily be added with zinc anode belts providing protection against galvanic corrosion. The cast parts of the pump can also be protectively coated, ensuring trouble free operation when pumping salty or brackish water.



Series connections for pumping high heads

With minimal effort, the standard ABS drainage pumps can be rebuilt to function in series connected applications for high head pumping.

This feature ensures a flexible use of your drainage pumps.

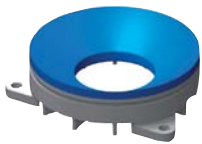

Polyurethane for prolonged life of the drainage pump

ABS offers diffusers and wear-rings in polyurethane, which increases resistance when pumping fine sand and other abrasive mediums. Polyurethane coated diffusers and wear rings are available as an option on J/JC 24-44, J/JC 54-84, J 205, J 405 and J 604.

Electronic motor supervision

The FSV 82, electronic motor protector prevents the pump from starting in the wrong direction of rotation. This protection device will also trip the pump in event of phase failure. The FSV 82 features protection against automatic restart in event that the pump has tripped due to over heating.

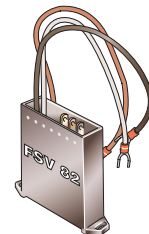

Bottom suction adapter

On pumps types J12, J15 and J24 the standard bottom plate may be replaced by a bottom suction adapter. A basement floor or a tank can be pumped practically dry with this adapter.

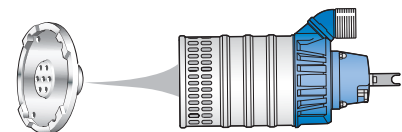

Save time and money on ABS repair kits

ABS offers repair kits to all submersible dewatering pumps. The repair kits includes pre-selected spare parts which secures a fast and efficient maintenance and avoids unnecessary downtime for the pump. The common known modular design with many interchangeable parts makes it possible to repair all drainage and sludge pumps just with a few repair kits.





Complete equipment supply for easy installation and convenient handling

ABS offers a variety of discharge connections/quick couplings in different size and style to suit your needs/ requirements. Choose from ABS flexible durable discharge hoses in sizes up to 10".



Easy installation with starter box and safe operation with level control

When a start and stop level is required, a starter box for level control can prolong the life of the pump. ABS provides standard DOL and star-delta starter boxes with a built in float switch for J/JC/JS/JT series. For the smaller J/JS pumps the level control function can be integrated in the pump.



SoftDrive for cost effective operation

ABS offers a built in SoftDrive concept on the J54 to J205 pumps. It reduces starting current dramatically and provides a smooth operation for both the power net and pump equipment. The pump can be started with a smaller sized generator compared to a standard direct on line started pump.

Plug and pump with ABS carry case kit

ABS pump model J12 and J15 are available as a complete carry case kit including pump, discharge connection, hose, couplings, lifting rope and bottom suction adapter. It is easily carried to site in a case including all parts needed to get the pump up running.



Quick and easy installation with ABS floatation ring

ABS floatation rings offers a solution for pumps up to 55 kg. The floatation ring is easy to install and can be used to any of ABS dewatering pumps J12 to J54. Other pumps may be used after checking the lifting capacity.



Let the pump float and avoid unnecessary wear with ABS floatation system

ABS floatation system offers a modular system and cover pumps from 70 to 600 kg. The modular floatation system is easy to build and use to any of ABS dewatering pumps J/JC 84 to J 604 and JS 54-84. Other pump types such as JT may be used after checking the lifting capacity.



222011 6850Hz-07.2010 The manufacturer reserves the right to alter performance, specifications or design without notice. © Copyright (2009) ABS.

